



DURAPLANK™ WEATHERBOARDS

Technical Specification | Apr 2015

Product Description

BGC Duraplank™ is a general-purpose Fibre Cement cladding designed for external applications. It is manufactured as a plank, which is reminiscent of traditional weatherboards both in appearance and installation methods. Unlike timber weatherboards, Duraplank™ is not subject to timber rot or decay and is non-combustible. The result is a safer, more durable cladding that requires minimal maintenance.

Duraplank™ is available in two styles - Smooth or a Wood grain (Douglas Fir) texture for that authentic timber weatherboard look. At 7.5mm thick, Duraplank™ has the strength to withstand the rigours of all normal family activities.



Compliance - At time of writing:

This document must be read in conjunction with and in accordance to:

Compliance Document for New Zealand Building Code (NZBC). Clause E2 – External Moisture, 3rd Edition, Amendment 6, Published 14 February 2014. In particular section 9.5 of Acceptable Solutions E2/AS1 for Fibre Cement Weatherboards. This document is limited to building within the scope of NZS 3604:2011 Timber-framed buildings.

Sheet Sizes & Mass

Duraplank™ is available in the following sizes. The approximate weight of Duraplank™ at equilibrium moisture content (7% moisture) is as tabulated.

| Thickness (mm) | Length (mm) | Sheet Width (mm) & Pattern | Mass (per length) |
|----------------|-------------|----------------------------|-------------------|
| 7.5 | 4200 | 180 Smooth | 9.24 |
| | 4200 | 230 Smooth & Woodgrain | 12.18 |
| | 4200 | 300 Smooth & Woodgrain | 15.98 |

Fire Resistance Rating

30 MINUTE FRR

To achieve a 30/30/30 FRR, Duraplank™ must be installed as follows:

Exterior face: Duraplank™ must be fixed in accordance with this specification as noted under the **Fasteners** section.

Timber Framing: Minimum 90mm deep x 45mm wide, in accordance with NZS 3604. Studs at maximum 600mm centres. Nogs/Dwangs at maximum 800mm centres. Double or staggered studs may be used.

Insulation: Any R2.2 nominal 95mm thickness fibreglass insulation.

Interior lining: 10mm GIB® Fyreline fixed as per Winstone Wallboards Ltd specification GBTL 30 system from GIB® Fire Rated Systems January 2006.

60 MINUTE FRR

Please contact BGC Fibre Cement (NZ) for 60 minute FRR details.

Framing

Duraplank™ is suitable for use with both timber and lightweight steel framing.

Duraplank™ shall be either direct fixed to framing over a wall underlay or fixed over a drained cavity system in accordance with NZBC as follows.

| Risk Matrix Score (NZBC – E2/AS1) | Fixing type |
|-----------------------------------|--|
| 0-6 | Direct fixed to framing |
| 7-20 | Fixed over nominal 20mm drained cavity |

Timber Framing Requirements:

- Studs must be provided at maximum 600mm centres
- Nogs/Dwangs must be provided at maximum 800mm centres (and 1200mm centres for direct fixing)
- When studs are at 400mm centres the nogs/dwangs may be provided at maximum 1200mm centres
- Double studs are required at internal corners when fixing Duraplank™ without drilling plank ends
- Extra packers may be required at external corners.

Fasteners

Duraplank™ must be fastened at every stud. Duraplank™ shall be fixed through the wall underlay to the framing at maximum 600mm centres. Fasteners must not be placed closer than 12mm from the plank edge.

Nails must not be driven closer than 50mm from the plank end. Nails or fasteners can be located 20mm minimum from the plank end if the fastener hole is predrilled using a 3mm titanium drill bit.

Except for straight joints, planks must be fixed a maximum of 100mm from the plank end.

Fixing to Timber Framing:

| Fixing Method | Fixing | Fixing Pattern |
|---------------|-----------------------------|---|
| Direct Fixed | 50 x 2.8mm Flat Head nails | Single fixing 20mm above lower board, through both thicknesses. |
| Over Cavity | 75 x 3.15mm Flat Head nails | |

- Cavity battens will be fixed by the Duraplank™ fasteners. These must penetrate the wall framing
- All fasteners must have a minimum framing penetration of 35mm
- Fasteners must be increased in length when using a rigid sheathing / air barrier such as BGC Durabarrier™
- All nails must be driven flush with the plank surface.

Fixing Material Type:

| NZS 3604 Climate Zone | Fixing Material |
|-----------------------|--|
| B, C & D | Hot-dipped galvanised steel |
| - | 304 Stainless steel is recommended for exposed sea spray areas |

Fixing to Lightweight Steel Framing: Please refer to the separate BGC Steel Framing Technical Specification for information relating to fixing of BGC Fibre Cement products to lightweight steel framing.

Pre-installation

Wall underlays: Wall underlays must be provided as per the requirements of the NZBC. Rigid wall underlays, in association with drained cavities are required in Extra High wind zones. Rigid underlays are also required to external walls of attached garages that are unlined.

BGC Durabarrier™ is ideally suited for use where a Rigid Wall Underlay or Air Barrier is required. Please refer to the separate Durabarrier™ documentation on use of this product.

Flashing requirements: Prior to Duraplank™ installation, all internal and external corners along with all wall openings and penetrations such as, window and door openings (head, sill and jamb), junctions, intersections and the like must, be flashed.

Wall underlays and flashings shall comply with the requirements of the NZBC and NZS 3604. In conjunction with, installation shall be in accordance with the manufacturer's instructions.

BGC accept no responsibility for water infiltration within the building due to poor workmanship or incorrect installation of flashings or wall underlays.

Cavity Battens: Where a drained cavity is required the cavity battens must comply with the NZBC and shall be nominal 20mm thick (18mm minimum). The battens must also be a minimum of 45mm wide and are to be fixed by the cladding fixings, through the wall underlay into the framing.

Cavity spacers may be needed where fixing is required between cavity battens.

Laps and Joints

Duraplank™ must be installed with horizontal laps of 30mm minimum. Joints shall be positioned between studs, be staggered at 600mm minimum from joints in adjacent planks and be weatherproofed by using uPVC H jointers or metal backed soakers. Sealant must be applied between the plank ends and be in accordance with NZBC E2/AS1.

Installation

Duraplank™ shall be installed as follows, in conjunction and in accordance with other product manufacturers' specifications and instructions.

- Fix all flashings to wall openings including external and internal corners
- Install wall underlay
- Where a drained cavity is required, install cavity battens
- Where a drained cavity is required, install a cavity vent strip (with opening area of 1000mm² per metre length)
- Fix a starter strip (timber or a strip of plank) to the bottom plate to ensure the first row of planks is packed out to the correct angle. This starter strip is to be continuous around the perimeter of the building and to overhang the foundation by minimum 50mm
- Set a horizontal datum line around the perimeter of the building using a string line or spirit level. Fix guide nails/screws along this line to act as a stop for the correct placement of the first course of planks.
- Commence fixing the bottom course of plank from an external corner. Fasten the bottom edge of the plank to each stud through the starter strip. Ensure the plank is level and flush with the corner. Do not nail home the corner fixing at this time
- Fit the plank joiner (off stud soaker or PVC joiner) to the end of the plank and continue fixing the bottom course
- If using preformed aluminium corners, insert these before nailing home the corner fixing
- The plank must overlap a minimum of 30mm, and before fixing the second row of planks calculate the overlap so a near full width of plank will finish at the top of the wall. Using a piece of timber or plank, fabricate a lap gauge to ensure the plank coverage is uniform
- Commence fixing the second row of planks from an external corner using this lap gauge. Use a shorter length of plank than the bottom course to allow for staggered end joints. Continue fixing the Duraplank™ around the building following these methods
- Fixings must be not be driven closer than 50mm from the end of the plank. For fixings between 20-50mm from the end, the plank must be predrilled with a 3mm hole
- When fixing Woodgrain Duraplank™, the pattern is repeated every 4th or 5th plank. To achieve a genuine Douglas Fir pattern, avoid starting each course with a new plank and rotate to avoid pattern repeats.

Preparation and Painting

Painting of Duraplank™ is required to meet the durability and external moisture requirements of the NZBC.

Duraplank™ must be painted within 3 months of installation. When using uPVC flashings, the light reflective value of the colour used must be more than 40% as required under E2/AS1. Darker colours can cause excessive movement and reduce the cladding performance.

It is recommended that only quality sealants that comply with the NZBC be used – preferable BRANZ appraised products. The sealants manufacturers' instructions must be followed.

Quality Paints that comply with AS 3730 should be used and manufacturers' specifications must be followed. All surfaces should be free from dust and contaminants prior to painting.

BGC Fibre Cement manufactures and grades Duraplank™ to strict quality control measures. The installer is responsible to ensure it will meet the required finish prior to installation. BGC will not be responsible to correct self-evident surface issues after installation.

Maintenance

Duraplank™ when used in accordance with this literature requires minimal maintenance. Building Owners are responsible for the maintenance of claddings.

Annual Inspections must be made to ensure all aspects of the cladding system (including flashings) remain in a waterproof condition. Any damaged areas or areas showing signs of deterioration which would allow water ingress, must be repaired immediately. Damaged planks should be replaced as originally installed.

Flashings and sealants must continue to perform their design function and must be repaired in accordance with the relevant manufacturers' instructions.

Regular cleaning (at least annually) of the paint finish with water and a mild detergent is recommended to remove grime, dirt and organic growth, to maximise the life and appearance of the cladding.

Pictorial Figures

Following are pictorials taken from section 9.5 of the NZBC Acceptable Solutions E2/AS1.

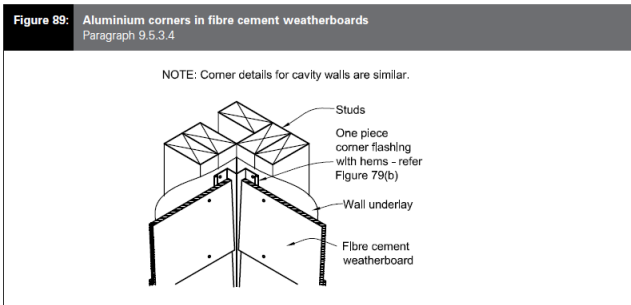
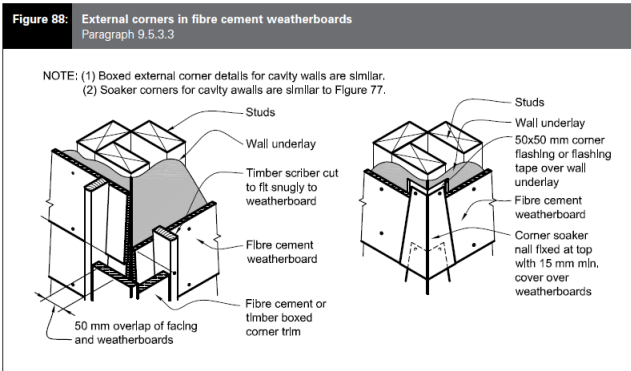
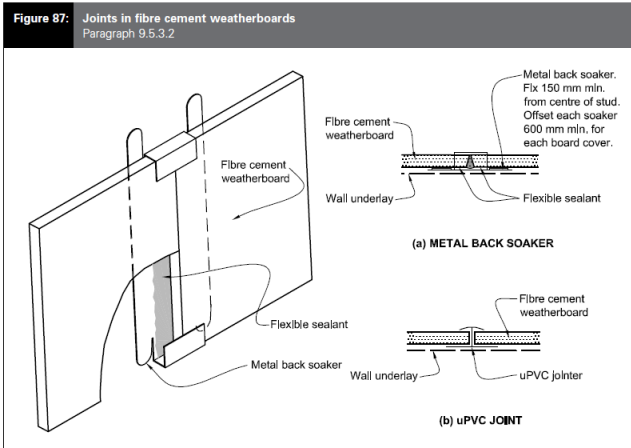

Recoating of the paint finish will be necessary throughout the life of the cladding system. Repaint in accordance with the paint manufacturer's instructions. When re-painting, care must be taken to ensure the bottom edges are well covered.

Warranty

BGC warrants Duraplank™ to be free from defects caused by defective manufacture or materials for a period of 15 years from the date of purchase. Furthermore, BGC warrants its products to be resistant from rotting, fire and cracking so long as the installation is carried out in accordance with BGC literature available at the time of purchase.

This warranty is subject to conditions as set out in a separate document. For a copy of this information and/or a copy of the quality control measures, please contact BGC Fibre Cement (NZ).

